

453252 ISS T 10.08

NOTE: _____

Speed: **n=1450⁻¹ 50 Hz**
 Impeller: **Max. dia 230 mm**
 Min. dia 160 mm
 Pump inlet: **101,6 mm**
 Pump outlet: **76 mm**

Performance data refer to water at 20°C
 Permissible tolerance ±5%

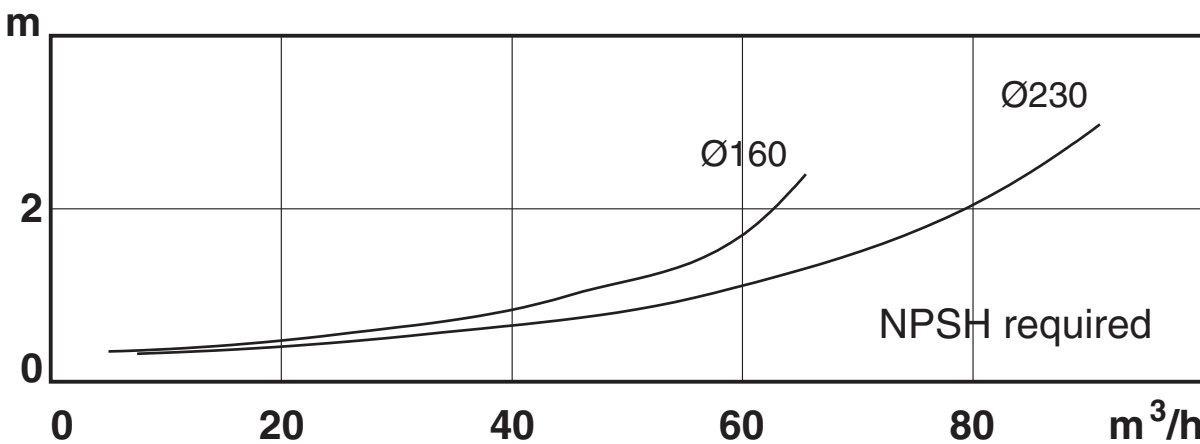
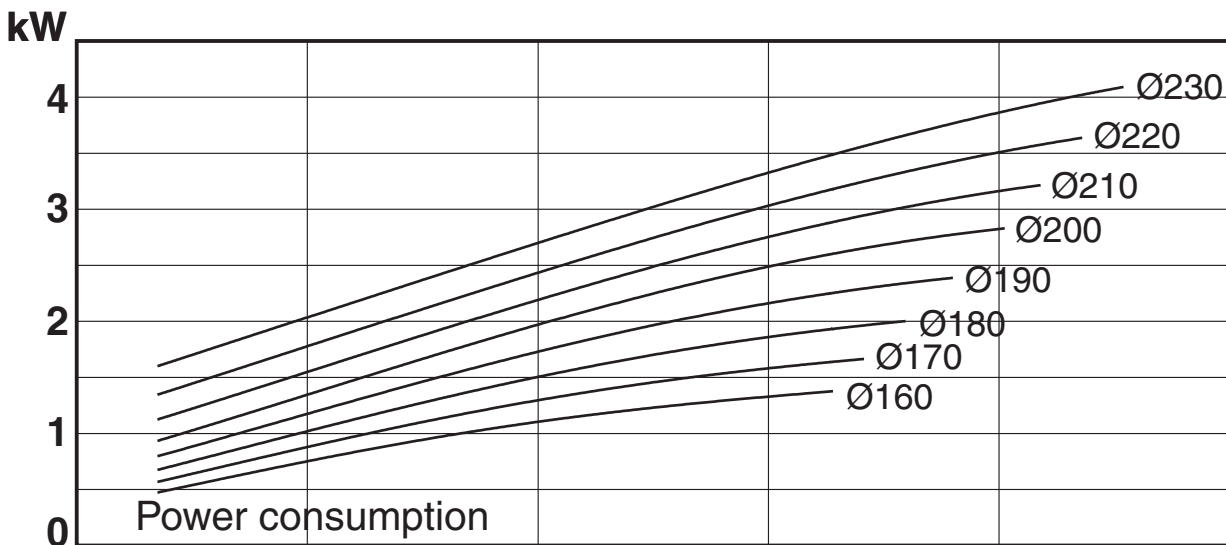
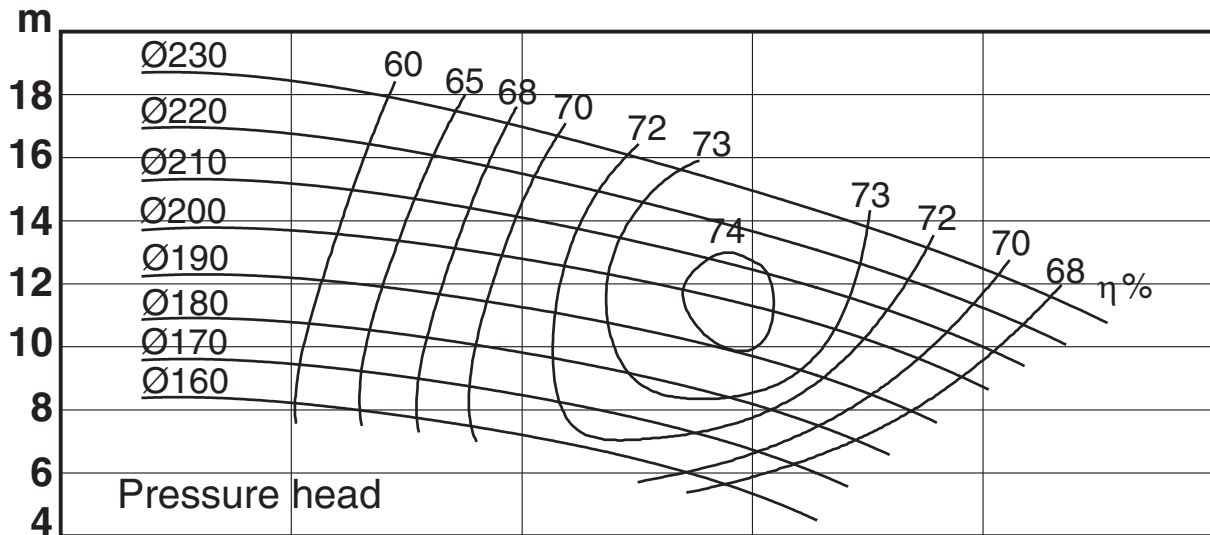

453252 ISS T 10.08

NOTE: _____

Speed: **n=2900⁻¹ 50 Hz**
 Impeller: **Max. dia 230 mm**
 Min. dia 160 mm
 Pump inlet: **101,6 mm**
 Pump outlet: **76 mm**

Performance data refer to water at 20°C
 Permissible tolerance ±5%

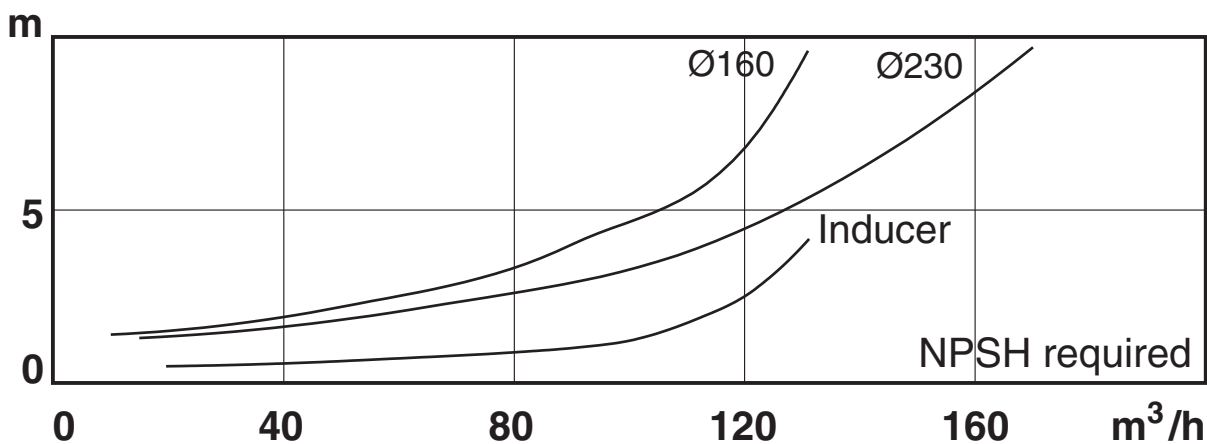
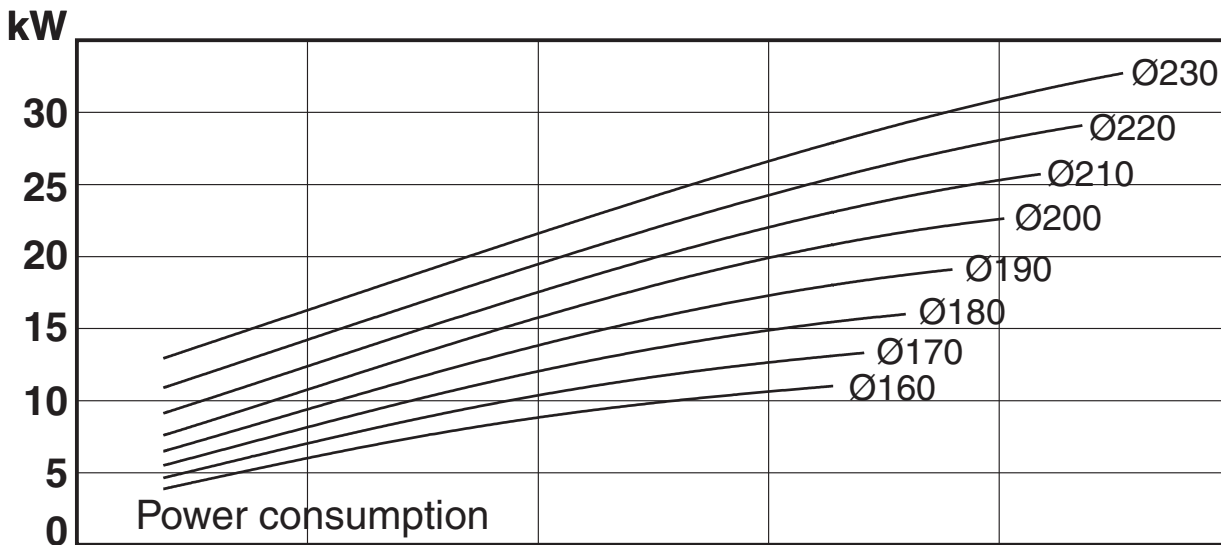
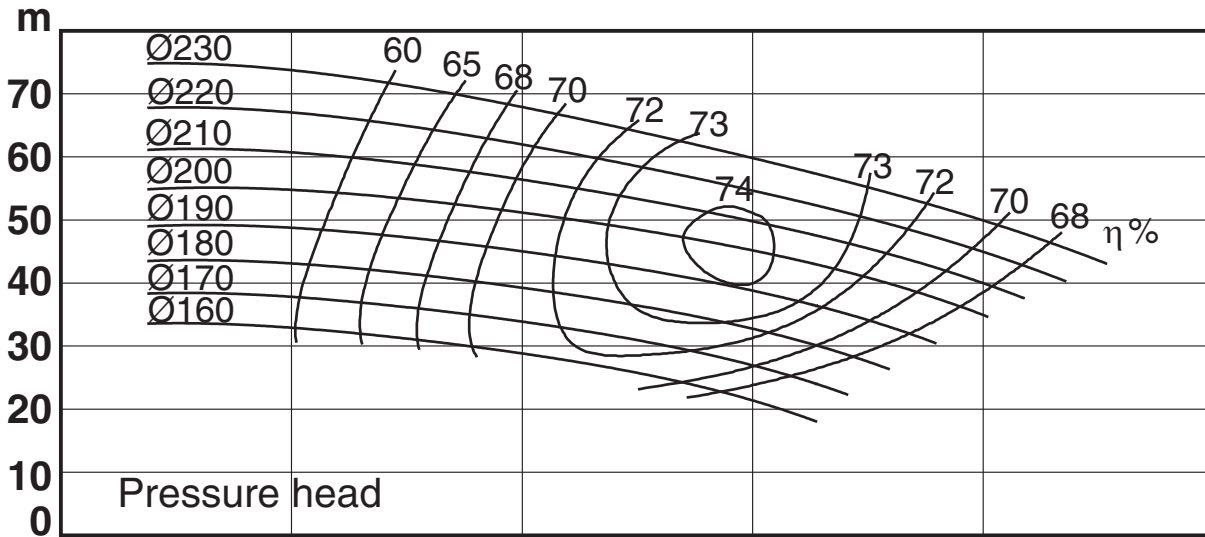

453252 ISS T 10.08

NOTE: _____

Speed: **n=1750⁻¹ 60 Hz**
 Impeller: **Max. dia 230 mm**
 Min. dia 160 mm
 Pump inlet: **101,6 mm**
 Pump outlet: **51 mm**

Performance data refer to water at 20°C
 Permissible tolerance ±5%

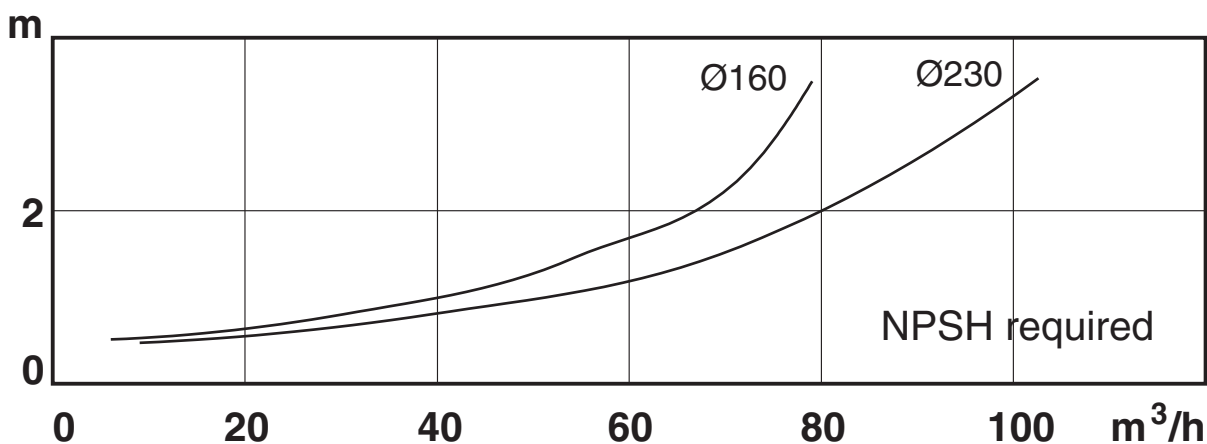
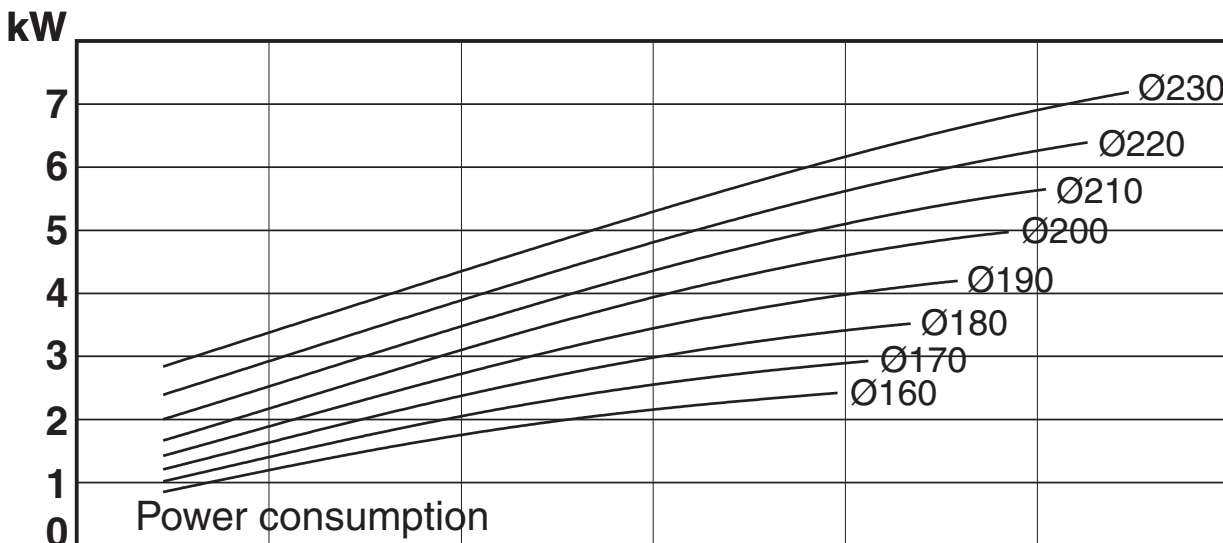
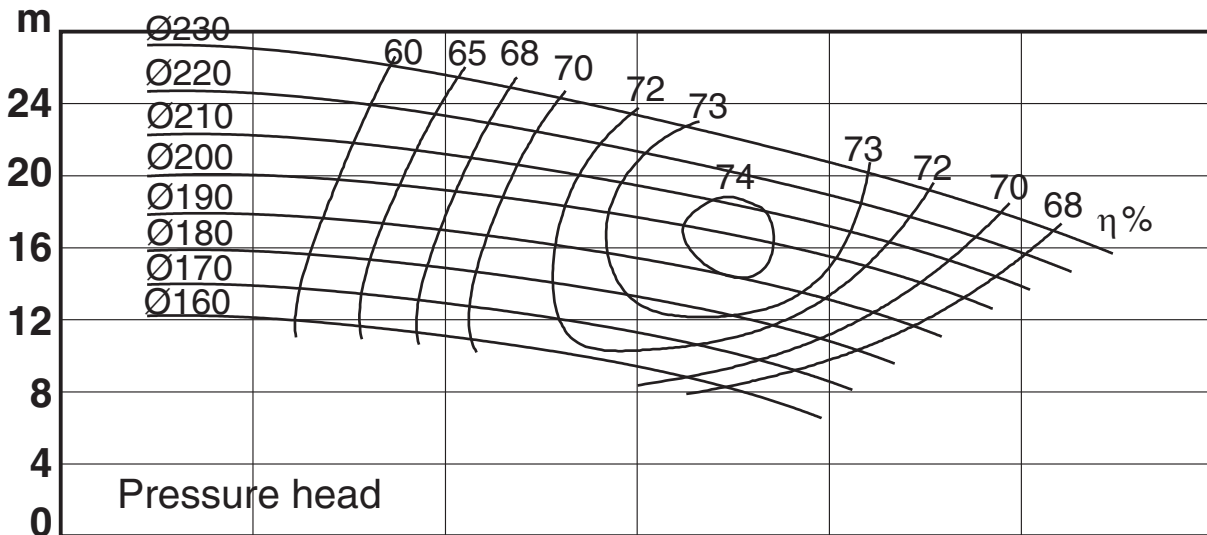

453252 ISS T 10.08

NOTE: _____

Speed: $n=3500^{-1}$ 60 Hz
 Impeller: Max. dia 230 mm
 Min. dia 160 mm
 Pump inlet: 101,6 mm
 Pump outlet: 51 mm

Performance data refer to water at 20°C
 Permissible tolerance $\pm 5\%$

